

SILENCER SHEETS

DESCRIPTION

Vibro-Acoustics' RLP and CLP silencers have 100% of the glass fiber or expansion chambers outboard of the airstream. By allowing the silencer outboard dimensions to exceed the duct cross section dimensions, and maintaining internal dimensions equal to the connecting duct dimensions, RLP and CLP silencers will have a pressure drop almost equal to empty duct. The difference is only the roughness factor of perforated metal over solid.

RLP and CLP silencers can be straight or also include bends and transitions. The most common thickness of acoustic treatment is 4" for noise control. Thicker treatment of 6" or even 8" is more effective in the low frequency range. It is usually applied to all four walls. For higher duct aspect ratios, application to the larger two walls could suffice.

RLP-D and CLP-D silencers use acoustic grade glass fiber protected by perforated metal. The thick media provides excellent attenuation if sufficient length is available at virtually no pressure drop. Glass fiber cloth in addition to the perforated metal prevents glass fiber erosion above 4000 fpm for straight ducts and 2000 fpm at elbows and other fittings.

RLP-FL and CLP-FL silencers incorporate a film liner between the perforated metal and the glass fiber. RLP-NM and CLP-NM silencers do not use glass fiber and are completely void of any fill material.

APPLICATION

- ◆ high duct velocity systems (see SAS 7)
- ◆ when fan system can not tolerate too much pressure drop (see SAS 8)
- ◆ systems with long duct runs
- ◆ when long term energy cost and initial incremental system cost is more important than initial silencing cost
- ◆ to save redesign of equipment room when standard silencers can not fit the space
- ◆ where break-out or break-in noise is of concern

FEATURES AND BENEFITS

- ◆ fully external acoustical media allows very low pressure drops
- ◆ available in any cross-sectional dimensions to "fit-the-duct"
- ◆ made in sections to fit ceiling space and can incorporate notch-outs to facilitate cross-over beams, pipes, ducts, etc.

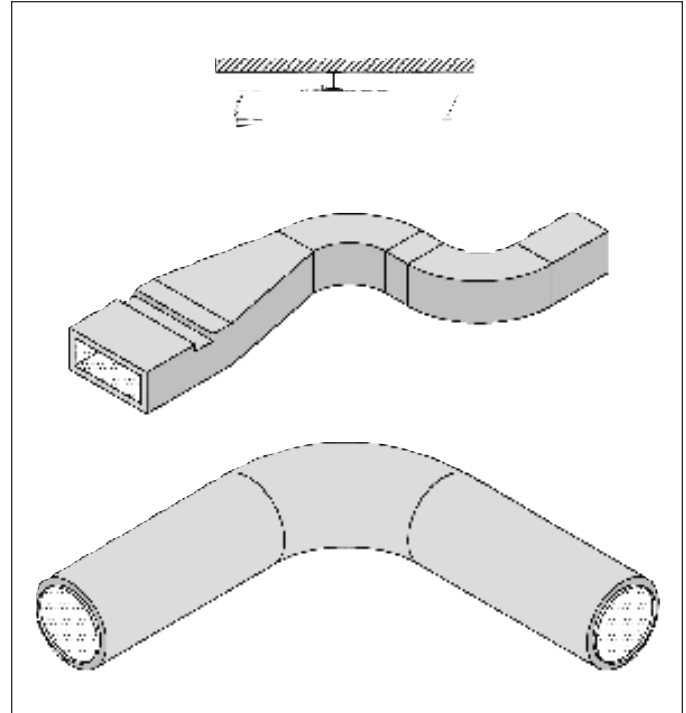

- ◆ can be selected to suit the acoustic, space, or energy-cost requirements
- ◆ construction quality and aerodynamic design optimized to give reliable performance, best acoustics, lowest pressure drop and lowest overall cost
- ◆ available in Dissipative (RLP-D and CLP-D), Film Lined (RLP-FL and CLP-FL) and No-Media (RLP-NM and CLP-NM) options

CAUTIONS / WHEN NOT TO USE RLP AND CLP SILENCERS

- ◆ when there is absolutely no room outside the duct connection size (e.g. tight shafts)
- ◆ when there is not enough duct length consider using Fan Silencers (SS10 and SS11) or EX Model Silencers (SS8)
- ◆ when break-out noise is of prime concern RLP and CLP silencers may be appropriate selections. They may require mass/stiffness added to their outer casing (see HTL Silencers (SS7))

SILENCER SHEETS

TESTING

Vibro-Acoustics' 4th generation aero-acoustic laboratory was the first laboratory to be NVLAP accredited for the ASTM E-477 silencer test code. NVLAP is administered by the U.S. Dept. of Commerce. See the Corporate/Laboratory Section.

SILENCER SELECTION AND LOCATION

RLP and CLP Silencers need to be carefully selected to optimize performance. Call 1-800-565-8401 for custom selections by our application engineers.

SPECIAL CONSTRUCTION OPTIONS

- ◆ heavier gauge casings and perforated metal
- ◆ continuously welded casings
- ◆ special materials e.g. stainless steel, aluminum
- ◆ flanges
- ◆ access doors
- ◆ media protection: glass fiber cloth
- ◆ high transmission loss (HTL) casings to prevent break-out/break-in noise
- ◆ built-in transitions
- ◆ removable splitters
- ◆ flow measuring stations
- ◆ for details of above and more special options see Special Construction Options (pg. 3.33 to pg. 3.37).

TO SPECIFY

See example specification located in the Selection/

STANDARD CONSTRUCTION FEATURES

RLP-D and CLP-D

- ◆ galvanized, lockformed casing constructed to SMACNA standards
- ◆ 1" slip connection at each end
- ◆ perforated galvanized liner matching the inside duct cross sectional dimensions
- ◆ acoustic grade glass fiber under minimum 15% compression with thickness usually ranging from 2-8" depending on acoustic performance required and space available

RLP-FL and CLP-FL

- ◆ galvanized, lockformed casing constructed to SMACNA standards
- ◆ 1" slip connection at each end
- ◆ perforated galvanized liner matching the inside duct cross sectional dimensions
- ◆ acoustic grade glass fiber under minimum 15% compression with thickness usually ranging from 2-8" depending on acoustic performance required and space available
- ◆ glass fiber carefully wrapped in Tedlar film with lap joints away from perforated metal edges to reduce potential tearing of the Tedlar
- ◆ 0.5 inch deep corrugated honeycomb "stand-off" spacer sheet placed between the perforated metal and the film

RLP-NM and CLP-NM

- ◆ galvanized, lockformed casing constructed to SMACNA standards
- ◆ 1" slip connection at each end
- ◆ special "tuned" perforated galvanized liner matching the inside duct cross sectional dimensions
- ◆ "tuned" chambers external to the duct cross sectional dimensions
- ◆ no acoustical media